

# Zombie Land

## MANUAL



### Warning

- ✧ Please read the manual before installation and use.
- ✧ Please put the manual together with the machine.



**ACE AMUSEMENT**

**ACE Amusement Technologies Co., Ltd.**

ADD: #5 Building, No. 6, HengFeng 6<sup>th</sup> Road,  
Gangkou Town, Zhongshan City, Guangdong,  
P. R. China PC: 528447

TEL: (+86) 760 8848 8920

E-Mail: Sales@ACE-Amusement.com

Web: [www.ACE-Amusement.com](http://www.ACE-Amusement.com)

# CONTENTS

<b>Introduction .....</b>	<b>1</b>
<b>Specifications and Technical Parameters .....</b>	<b>3</b>
<b>Accessory List .....</b>	<b>4</b>
<b>How to Move and Position the Machine .....</b>	<b>5</b>
How to Move the Machine.....	5
How to Position the Machine .....	6
Unsuitable places.....	6
Where to Place.....	6
Installation Location Dimension .....	7
Precautions before Startup .....	7
<b>Wiring and Precautions.....</b>	<b>8</b>
<b>Installation and Maintenance .....</b>	<b>10</b>
<b>Troubleshooting .....</b>	<b>12</b>
<b>Instructions on Game .....</b>	<b>14</b>
<b>Adjustment of Game Program Setting .....</b>	<b>20</b>
<b>Error Prompt.....</b>	<b>28</b>
<b>Main Part Picture .....</b>	<b>29</b>
<b>Exploded View of The Complete Machine.....</b>	<b>31</b>
<b>Assembly Figures and Steps.....</b>	<b>32</b>
<b>I/O Board List.....</b>	<b>44</b>
<b>Instruction on Restoring U Disk .....</b>	<b>45</b>

# Introduction

## I. Company Profile

Thank you for choosing the amusement machine produced by our company. We are a comprehensive enterprise integrating development, production, sales, operation and services. “Quality first, users first, services first” is our solemn promise to customers and our action guide.

Please carefully read the manual for correct, appropriate and safe use of the machine. We hope it can help you to succeed!

## II. Introduction to the Product:

Zombie Land, an indoor simulation amusement machine newly developed by our company and especially designed for the public amusement, is novel and beautiful in appearance, safe and reliable, and easy to operate, so it is the best amusement product in the amusement park.

## III. Features of the Product:



- ✧ Novel gameplay full of fun;
- ✧ Elegant appearance, bright-colored and exquisite patterns, materials used MDF, angle iron, truss and metal plate, safe and durable due to rust-proof treatment;
- ✧ Large-scale integrated circuit, built-in program, stable and reliable working performance;
- ✧ Sophisticated and adjustable game program and win ratio.

## IV. Note on Safety:

Before use, please note the safety warning stickers on the machine; while reading the manual, please pay special attention to some signs. We divide the safety warnings into 3 categories as follows. They mean different levels of danger.

- **Danger** It means there will be danger of harm to people due to improper operation.
- **Warning** It means there will be possibility of harm to people due to improper operation.
- **Attention** It means there will be possibility of harm to people or the machine due to improper operation.

### Please pay attention to the following signs on the machine:

High temperature sign	High voltage sign
	
No touching sign	
	

# Specifications and Technical Parameters

Unit: mm

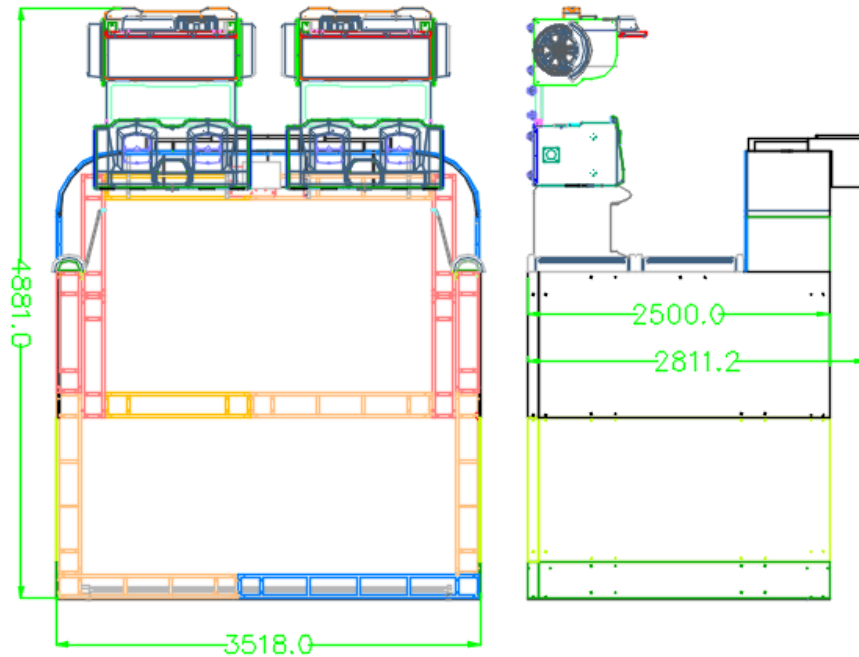

- 1) Operating voltage: AC220V—240V 50/60 Hz
- 2) Minimum power : 700W
- 3) Maximum power: 1000W
- 4) Dimensions: W3518×D4881×H2812 (mm)
- 5) Weight: About 1000kg
- 6) Operating environment: Temperature (indoors): 0°C ~ 35°C ;  
Humidity: ≤90% ;  
Atmospheric pressure: 86Pa ~ 106Pa。





**⚠ Warning:** After turning off the machine, please wait 3 minute if you want to turn it on.

**⚠ Attention:** The above technical parameters are subject to change without prior notice.

## Accessory list

For the normal use of the machine, please open the package and carefully check whether the following items are included.

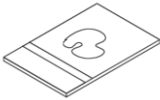
The accessory list is below:

No.	Name	No./Specification	Quantity	Unit	Picture	Remark
1	Cable	10A/250V-3M	1	Piece		
2	Fuse	Φ5×20mm T10A 250VAC	1	Piece		
3	Manual	English	1	Piece		
4	Key	AA33	2	Piece		
5	Key	AA32	2	Piece		

Please open the package and check whether all accessories are included. If not, please contact the distributor of the machine for check.

 **Attention:** The above technical parameters are subject to change without prior notice.

## How to Move and Position the Machine

### How to Move the Machine

There are trundles under the machine. When moving the machine for a short distance, you should raise foot to make the trundles touch the ground and push the machine. As there will be danger of overturning when the foot hits obstacle on the ground, you should move the foot up as much as you can and pay attention to obstacles ahead and uneven places when moving the machine along the ground.

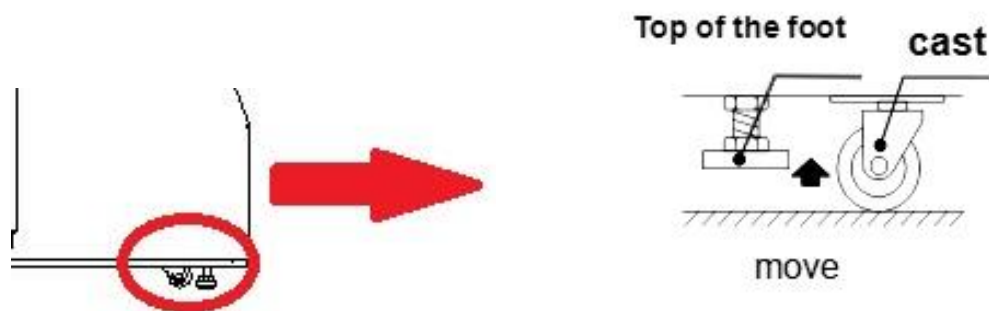

When moving the machine for a short distance, you should raise the foot to make the trundles touch the ground and push the machine.

When you move the machine and pass uneven places or place with steps, 4 people or more are needed to lift the machine for safety.



**Please unplug the power socket before moving to prevent accidents and failure.**

**Please do not damage the cable when moving to prevent accidents and failure.**

**Please move the machine before raising the foot margin as much as you can to prevent accidents and failure.**

**The machine shall be moved by at least two people to prevent injury caused by the accident.**

## How to Position the Machine

- Please place it on flat ground where it won't slide easily;
- Please use the following foot to fix the machine (as shown below)
  - ① Loosen the tightly locked nuts of the foot, tighten the bolts of the foot with a wrench, and keep the trundle approximately 5mm away from the ground.
  - ② Tighten the nuts clockwise and fix them.

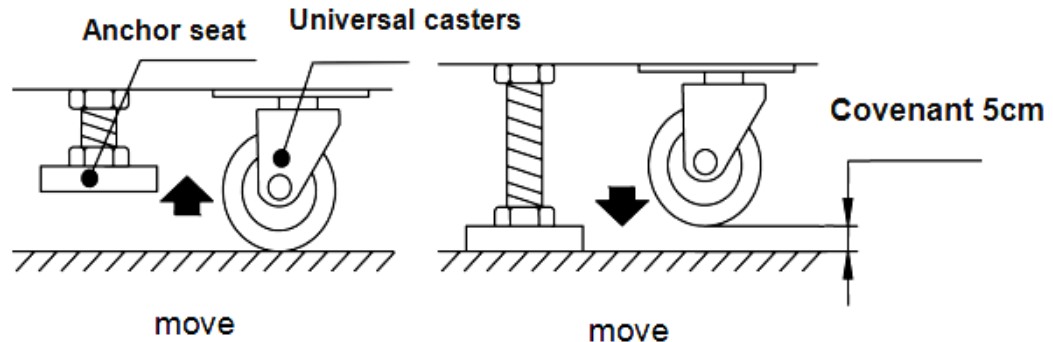

## Unsuitable Places

- Place in which the machine may have condensate water or with high humidity;
- Place close to high-temperature objects;
- Place close to dangerous substances;
- Smooth or unstable place;
- Place close to equipment that may easily produce sparks;
- Place with heavy vibration;
- Dusty place.

## Where to Place

**⚠ Warning:** The machine is only suitable for indoor use, not outdoor use.

**⚠ Warning:** Please do not use the forklift to move the machine, otherwise it may be damaged.



## Installation Location Dimension

The machine should be placed according to the following dimensions for customers' safety and enough space to run the machine.

Game area: 300mm

Unit: mm

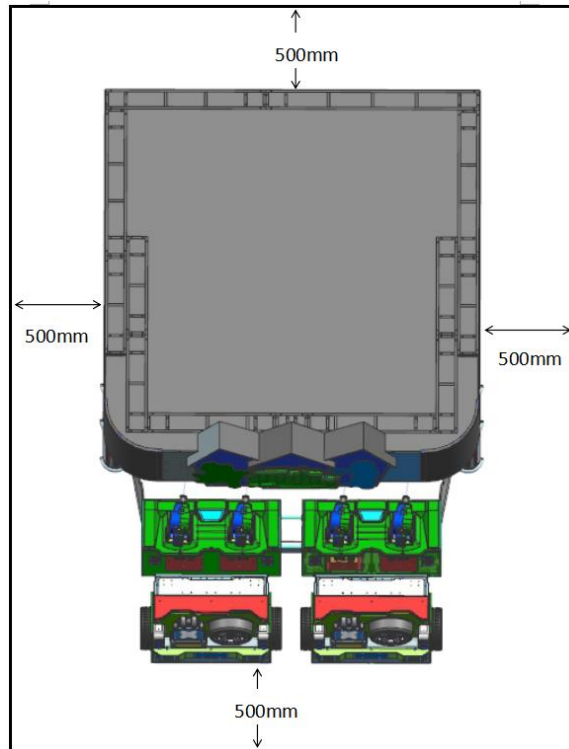

**⚠ Attention:** The machine should not be placed at inclined place, or there may be an accident.

**⚠ Attention:** The division of the game area should refer to labels of each machine.

## Precautions before Startup

- 1) Check parameters of the power supply. Ensure parameters of the machine meet the requirements, or the machine might be damaged or there might be fire accident.
- 2) Excessive loads on a power socket might cause socket overheat and fire accident.

## ⚠ Warning

- © Do not change or replace parts by yourself when installing the machine to prevent fire accident or short circuit.

## Wiring and Precautions

- Connect one end of the cable to the terminal box of the machine, and connect the other end to the socket.
- Connect the power supply according to the voltage on the label, or the machine might be damaged.
- Please confirm whether there is grounding in the socket to avoid unnecessary damage.
- If the grounding cannot be done through the socket, please try other methods.

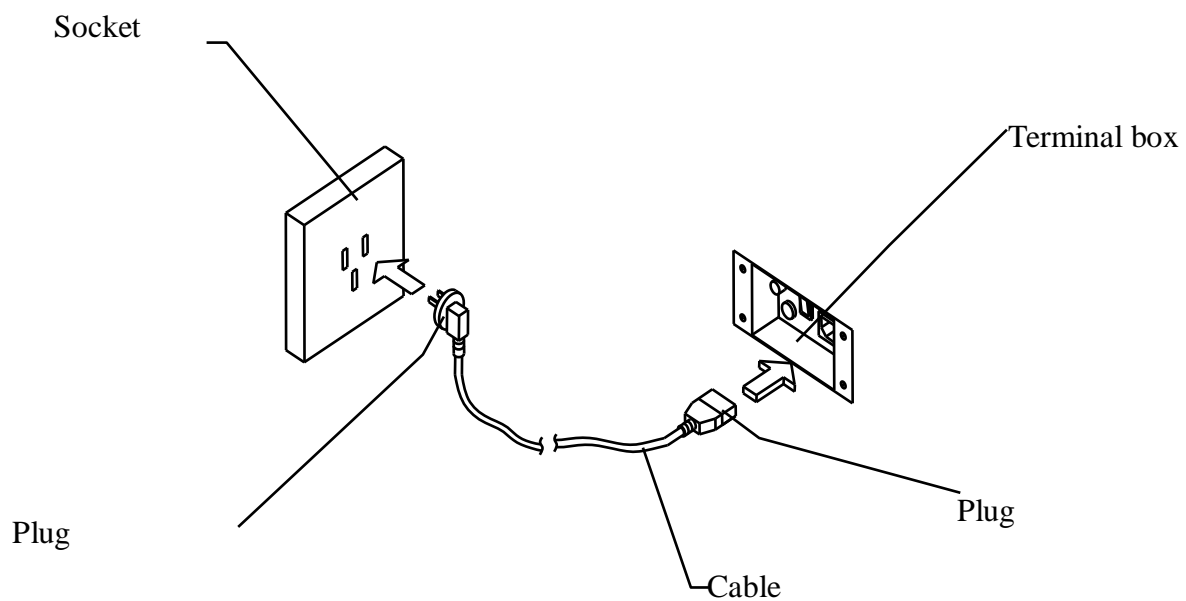

**⚠ Warning: The working voltage of the machine is 220V. Please connect the power supply according to the label, or the machine might be damaged.**

 **Attention:**

- The cable cannot be pressed by heavy objects, or it might be easily damaged and cause short circuit, and even fire disaster.

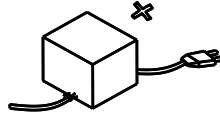

- When unplugging the cable, you should grasp the plug instead of the cable.

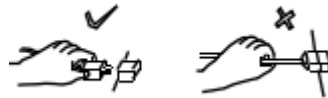

- It is not allowed to directly unplug with wet hands.



- It is not allowed to forcibly stretch, twist or expose the cable, or put it close to high-temperature objects.

- It is not allowed to put the cable at places where it may be easily kicked or touched.



- Use correct voltage and fuse (refer to technical parameters).

# Installation and Maintenance

## Installation and commissioning

- Please check the accessory list to assemble components before installation;
- The ground must be flat and solid. After placing the machine, adjust the feet to the ground and horizontally fix it;
- After installation, plug the cable and turn on the machine to check whether each part runs well. If no, immediately turn off the machine for troubleshooting.

## Visual inspection

To safely use the machine, please check the following before startup:

- Whether the warning sign is intact, visible and stuck correctly.
- Whether parameters of power supply are consistent with the machine's.
- Whether screws of each component and components of the steering wheel are loose.
- Whether the connectors and terminals are loose.
- Whether the machine is placed stably; whether the adjustment of the trundle and the top foot is proper.
- Whether the machine is placed properly.

## Operation inspection

- Whether the speaker works normally.
- Whether the daylight lamp and the button light are on.
- Whether the image is clear and normal.

## Maintenance

- Before operation, confirm the machine runs normally and then use it;
- When there is dirt on the machine, wipe it with a soft cotton cloth with detergent;
- After the new machine has been used for one month, check whether each part runs normally;
- Often check the machine.

## Cleaning

- Housing  
Clean dirt on the surface of the machine with clean and soft cotton cloth.
- Display  
Clean the outside of the display with clean and soft □ Display screen with no water; anything with acid is forbidden to touch the surface of the display.
- Exhaust fan  
The exhaust fan is one of the main tools of dissipating heat inside the machine. It has to be clean and run normally with unobstructed outlet.

## Warning:

- **Cut off the power supply for maintenance and repair of the machine.**

To prevent short circuit, relevant personnel should cut off the power supply when touching internal components of the machine. If the operation requires power supply, it should meet the requirements of the user's manual.

- **Use proper parts for replacement.**

Improper parts may cause short circuit, and damage of the main board and the components.

- **Do not disassemble, assemble and change the equipment by yourself.**

It may cause short circuit and machine failure, and even fire disaster.

- **Do not place vases, cups, containers with water, chemicals or heavy objects on the machine.**

The spilt liquid may cause short circuit and damage of parts. Meanwhile, falling objects may injure people and damage the machine.

- **Do not place objects in the air outlet of the machine.**

- The blocked air outlet may cause temperature rise inside the machine, affect the normal operation of the game, and even damage the parts.

- **Do not repair the machine by yourself.**

It may cause short circuit or malfunction and other failure.

# Troubleshooting

## Common Failure

Phenomenon	Main cause	Solution
After the machine is powered on,(the power supply fan works), but the display is not on.	The projector is not powered on	Please reconnect the power cable or replace it with new.
	The signal wire of the projector is no connected or damaged	Please reconnect the signal wire or replace it with new.
After the machine is powered on, there is no response and the screen is not on	The power supply is inconsistent with the machine's parameters	Please check whether the power supply is consistent with the machine's parameters
	The fuse is burnt	Please replace the fuse
	The power supply is not connected	Please confirm the 220V power supply is connected and the power switch is on
	The signal wire of the display is not connected or damaged	The signal wire of the display is not connected or damaged
The machine is not powered on	Check whether the input of the 220V power supply is right. The short circuit is not allowed.	Please check whether the voltage of the circuit board inside the machine is normal
The control board is not powered on	Check whether the output of 5V, 12V and 24V of the power supply box is normal.	Please adjust the cable to the correct position
The projection screen has no raster	The cable of the projector might fall off or be loosen due to vibration	Please check the power supply circuit or replace the cable
	The display is not on	Turn on the machine manually or with the remote control
The image of the projector has a color difference	Whether the setting of the projector is wrong	Please adjust RGB colors on the menu or select color temperature again. Click AUTOSET key to enable the display to automatically adjust colors.
	The view angle of the projector has a deviation	Adjust the position of the projector
The power supply is suddenly cut off	The circuit protector works, while the power switch is off (note: when the abnormal current runs, the circuit protector cuts off the current)	Please turn on the power switch again. When the circuit protector repeatedly works, it means there is something wrong with the machine. Please contact the distributor
After the machine is powered on, the projector shows a white screen without image and sound	The host does not work	Please manually start the host
		<b>The host power supply is damaged or replace it</b>
		The memory bank of the main board is in poor contact
		Please contact professionals and the manufacturer if the main board is broken
No bullet comes out	The internal holder and the microswitch of the handle is broken	Please replace the handle or the microswitch (quick-wear part)
There is no sense of vibration when holding the gun	<b>24V power supply, control board of the vibration motor, vibration motor and circuit connector are in poor contact</b>	<b>The 24V power supply box is broken or replace it; the control board of the vibration motor is broken or replace it; the vibration motor is broken or replace it; check the circuit connector and plug it again</b>
Press the start button, and the game cannot start	The holder of the start button falls off or goes wrong; the switch cable falls off; the switch of the start button goes wrong	The holder of the button is broken or replace it; press and plug the switch cable; the switch of the start button is broken or replace it

Phenomenon	Main cause	Troubleshooting
The coin collector does not respond	The coin collector is damaged	Replace the coin collector
	The signal wire of the coin collector is loose	Check whether the signal wire of the coin collector is loose
	The IO control board is damaged	Replace the IO control board
Coins are blocked in the coin collector	The sample coin is not placed well	Please check whether the sample coin is placed well, or try another sample coin
	The coin slot is not aligned or deformed	Please check whether the coin slot is aligned or deformed, and adjust it
	The coin collector is not assembled properly. The red braking bar above the coin collector is pressed	Please re-insert it into the coin collector
The coin collector does not score	Check whether there is signal feedback	Please re-connect the coin collector. It will make a sound if there is signal
	The connected target board is not connected to the pull-up resistor	Please connect the pull-up resistor
	Check whether the token in the coin collector is the same with that inserted in the coin collector	Please replace it with proper token
	The gear of the switch (normally on, normally off) is incorrect	Please check whether the gear of the switch (normally on, normally off) is correct
	The outlet of the coin connector is in poor contact	Please check whether the outlet of the coin connector is in poor contact
The coin collector is unsmooth	Adjust the VR rotary button	Please adjust the VR rotary button clockwise
	Adjust the precision switch (SW3)	Please adjust the precision switch (SW3) to the normal gear
	The sample coin is not placed well	Please check whether the sample coin is placed well, or try another sample coin
Fake coins pass through the coin collector	Adjust the VR rotary button	Please adjust the VR rotary button counterclockwise
	Adjust the precision switch (SW3)	Please adjust the precision switch (SW3) to the precision gear
The speaker does not make a sound	Whether the circuit board of the power amplifier is powered on	Please turn on the switch of the amplifier circuit board to power on
	The volume is too low	Please turn on the volume
	Whether the audio connection port falls off or is damaged	Please re-connect the audio connection port
	The circuit board of the power amplifier goes wrong	Please replace the circuit board
	The speaker goes wrong	Please replace the speaker
No ticket fed	The ticket machine goes wrong or the switch is turned on wrong	Please replace the ticket machine or set the switch to the factory settings

## Instructions on Game



Game logo/standby image

<I>. Game interface:



1. UI interface of the player's status
2. The player's front sight to aim at the target
3. The current taskbar
4. Game props to increase the shooting power



## <II>. Characteristics of the machine:

- ☆ The scene map of the game is divided into four areas: City Center, Factory, Cemetery and Pharaoh's Tomb. After the corresponding story is completed in each area, the player can go to the next map.
- ☆ There are some hidden props which can produce very powerful damage.
- ☆ The player will face various zombies. Different zombies with different attacks make the player's sense of freshness and tension stronger.
- ☆ There are many bosses in the game, giving the player's much amusement of challenging.

## <III>. Scene

### 1. Scene-City Center



### 2. Scene-Factory



3. Scene-Cemetery



4. Scene- Pharaoh's Tomb



5.Scene-hospital



6.Scene-crazy road



## <IV>. Game play:

### 1. Standby image



### 2. Task pass image



3. Plot production before the pass. Press “Start” to skip the plot

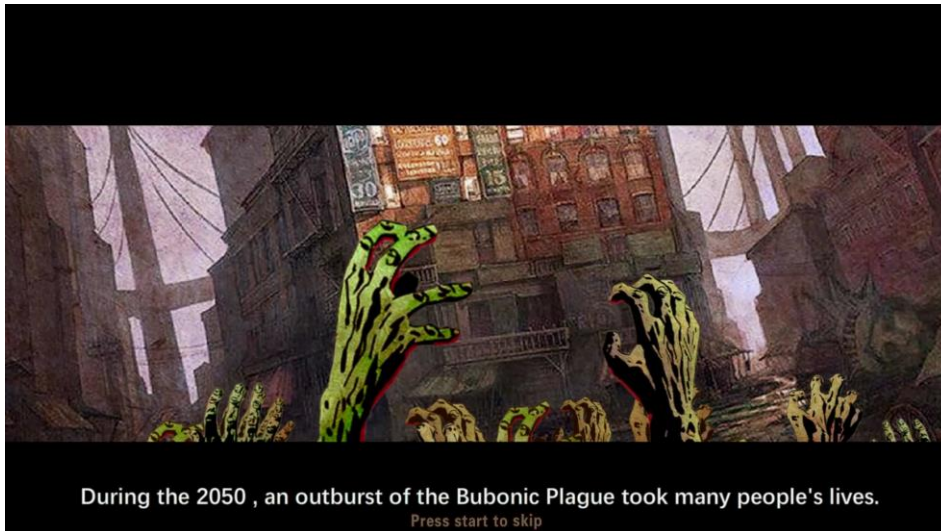

4. Game start image



5. Passes over. The rating interface



# Adjustment of the Game Back End

Option	KEY1	Test (choose)
	KEY2	Confirm (replenish lotteries)
	KEY3	Confirm (modify)
	KEY4	

## Main menu



- 1. Basic setting:** Enter the basic setting interface
- 2. Adjustment setting:** Enter the adjustment setting interface
- 3. Input test:** Enter the input test interface
- 4. Output test:** Enter the output test interface
- 5. Game reset:** Enter the game reset interface
- 6. Date/time setting:** Enter the date/time setting interface
- 7. Language:** Switch languages
- 8. Revenue record:** Enter the revenue record interface
- 9. Daily report:** Enter the daily report interface
- 10. Back to game:** Exit the back end and go back to the game interface

## Basic setting



### 1. Play for free: Choose the payment method

Turn off: The player needs to insert coins

Turn on: Press to start

### 2. Whether to feed lotteries: Choose whether to feed lotteries

Turn off: No

Turn on: Yes

### 3. Exchange lotteries with scores: Set the number of scores exchanged with 1 ticket

0~30000 Scope: 0-30000

### 4. The number of coins inserted in one game: Set the number of coins needed for one game

Scope: 1-10

### 5. Save and return: Save the data and return to the previous menu

### 6. Return: Return to the previous menu directly

## Adjustment setting



**1.1P Potentiometer adjustment: Adjust the 1P potentiometer**

**2.1P Potentiometer adjustment: Adjust the 2P potentiometer**

**3.1P Potentiometer adjustment: Adjust the 3P potentiometer**

**4.1P Potentiometer adjustment: Adjust the 4P potentiometer**

**5.1P Vibration strength Slow: Adjust the vibration strength of the 1P gun (for common shooting)  
Scope: 1-100**

**6.1P Vibration strength Fast: Adjust the vibration strength of the 1P gun (for intensive shooting)  
Scope: 1-100**

**7.2P Vibration strength Slow: Adjust the vibration strength of the 2P gun (for common shooting)  
Scope: 1-100**

**8.2P Vibration strength Fast: Adjust the vibration strength of the 2P gun (for intensive shooting)  
Scope: 1-100**

**9.3P Vibration strength Slow: Adjust the vibration strength of the 3P gun (for common shooting)  
Scope: 1-100**

**10.3P Vibration strength Fast: Adjust the vibration strength of the 3P gun (for intensive shooting)  
Scope: 1-100**

**11.4P Vibration strength Slow: Adjust the vibration strength of the 4P gun (for common shooting)  
Scope: 1-100**

**12.4P Vibration strength Fast: Adjust the vibration strength of the 4P gun (for intensive shooting)  
Scope: 1-100**

**13. Save and return: Save the data and return to the previous menu**

**14. Return: Return to the previous menu directly**



## Input test

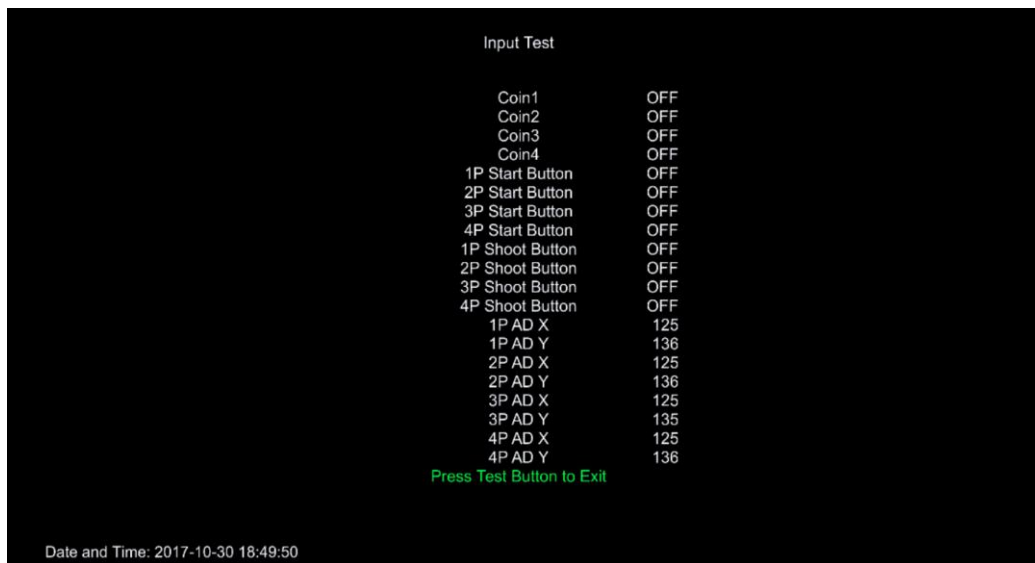

### 1. Insert coins 1: Test the 1P coin collector

**Turn off:** No inserting coins

**Turn on:** Inserting coins

### 2. Insert coins 2: Test the 2P coin collector

**Turn off:** No inserting coins

**Turn on:** Inserting coins

### 3. Insert coins 3: Test the 3P coin collector

**Turn off:** No inserting coins

**Turn on:** Inserting coins

### 4. Insert coins 4: Test the 4P coin collector

**Turn off:** No inserting coins

**Turn on:** Inserting coins

### 5.1P Confirmation button: Test the 1P confirmation button

**Turn off:** No pressing

**Turn on:** Pressing

### 6.2P Confirmation button: Test the 2P confirmation button

**Turn off:** No pressing

**Turn on:** Pressing

### 7.3P Confirmation button: Test the 3P confirmation button

**Turn off:** No pressing

**Turn on:** Pressing

**8.4P Confirmation button: Test the 4P confirmation button**

Turn off: No pressing

Turn on: Pressing

**9.1P Shooting button: Test the 1P shooting button**

Turn off: No pressing

Turn on: Pressing

**10.2P Shooting button: Test the 2P shooting button**

Turn off: No pressing

Turn on: Pressing

**11.3P Shooting button: Test the 3P shooting button**

Turn off: No pressing

Turn on: Pressing

**12.4P Shooting button: Test the 4P shooting button**

Turn off: No pressing

Turn on: Pressing

**13.1P Potentiometer X: Read the X value of the potentiometer 1P**

**14.1P Potentiometer Y: Read the Y value of the potentiometer 1P**

**15.2P Potentiometer X: Read the X value of the potentiometer 2P**

**16.2P Potentiometer Y: Read the Y value of the potentiometer 2P**

**17.1P Potentiometer X: Read the X value of the potentiometer 3P**

**18.1P Potentiometer Y: Read the Y value of the potentiometer 3P**

**19.2P Potentiometer X: Read the X value of the potentiometer 4P**

**20.2P Potentiometer Y: Read the Y value of the potentiometer 4P**

**21. Press the test button to exit: Press the test button to return to the previous menu**

## Output Test

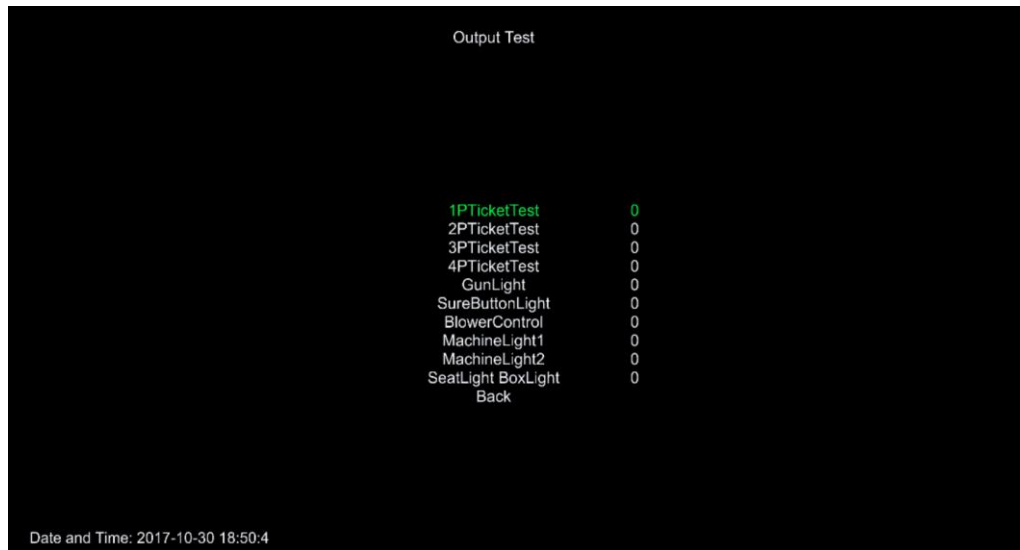

**1.1P ticket machine test: Test whether the 1P ticket machine works well**

**2.2P ticket machine test: Test whether the 2P ticket machine works well**

**3.3P ticket machine test: Test whether the 3P ticket machine works well**

**4.4P ticket machine test: Test whether the 4P ticket machine works well**

**5. Gun side light: Test whether the gun side lights on 4 positions work well**

**6. Confirmation button light: Test whether the confirmation button lights on 4 positions work well**

**5. Blower: Test whether the blowers on 4 positions work well**

**6. Machine light 1: Test whether the machine light 1 works well**

**7. Machine light 2: Test whether the machine light 2 works well**

**8. Seat light, light box: Test whether the seat light and the light box work well**

**9. Return: Return to the previous menu**

## Game Reset



1. **Restore to the factory settings:** Restore all data and settings to the factory settings
2. **Clear all data records:** Restore all data records to the default settings
3. **Clear the number of lack lotteries:** Clear the number of lack lotteries
4. **Clear unused coins:** Clear unused coins
5. **Return:** Return to the previous menu

## Date/time setting

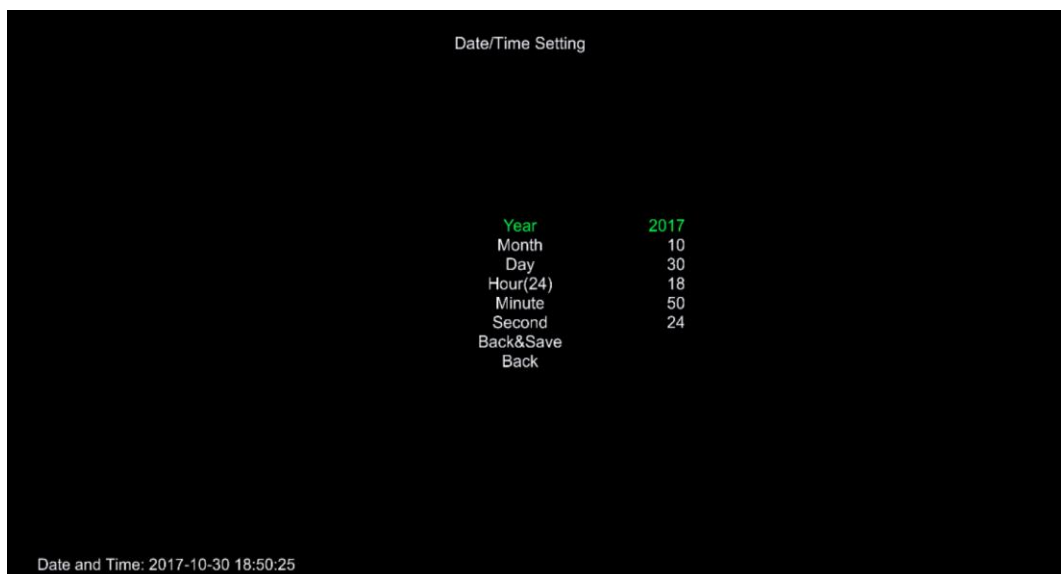

### 1. Set the time of the machine

Player	Coins	Tickets	Payout
1	12	0	0.00
2	0	0	0.00
Sum	12	0	0.00

Date and Time: 2017-10-30 16:38:10 Clear  
Back

### 1. Check game data

Date	Weekday	RunTime	Coins	Tickets	Payout
2017-10-30	MON	00:02	0	0	0

Date and Time: 2017-10-30 16:38:21 Clear  
Back

### 1. Check game data

Start Adjust! Remain 2 Point...  
X: 125 Y: 136

1.Shoot Left Down, Please Start Button  
2.Shoot Right Up, Please Start Button



### 1. Adjustment interface. Please adjust according to the prompt

## II. Error Prompt



1. Cause: Disconnection with the IO board
2. Solution: Restart the machine, and press the reset button on the IO board (there is only one button on the board)



1. Cause: The memory of the host is insufficient
2. Solution: Plug out the memory of the host, and then plug it in again.



1. Cause: No enough lotteries; the ticket machine is damaged
2. Solution: Replenish lotteries; replace the ticket machine

## Main Part Picture

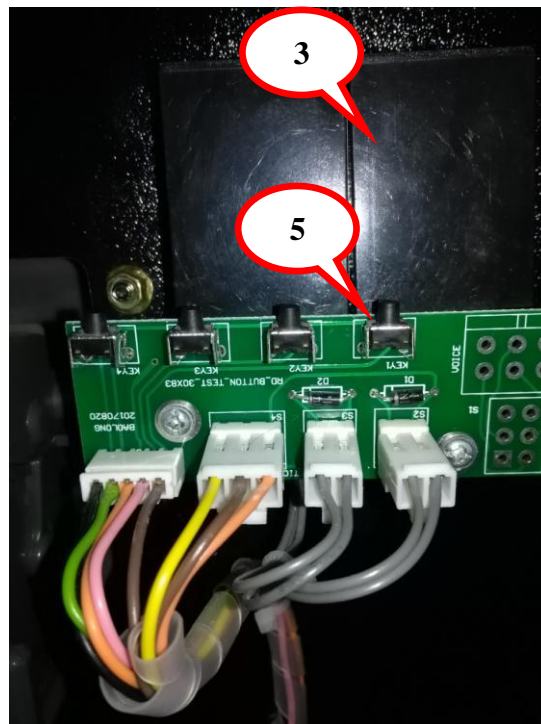

No.	Name	Specification	Quantity
1	Speaker	Whole tone, 4 inch, 4Ω, 25W	4
2	ticket machine	TL TL-001 generation 3rd	4
3	Counter	C-012 12VDC 18CPS (including diode)	2
4	Coin collector	TL TW-131	4
5	KEY1	Test (choose)	1
	KEY2	Confirm (modify)	1
	KEY3	Confirm (modify)	1

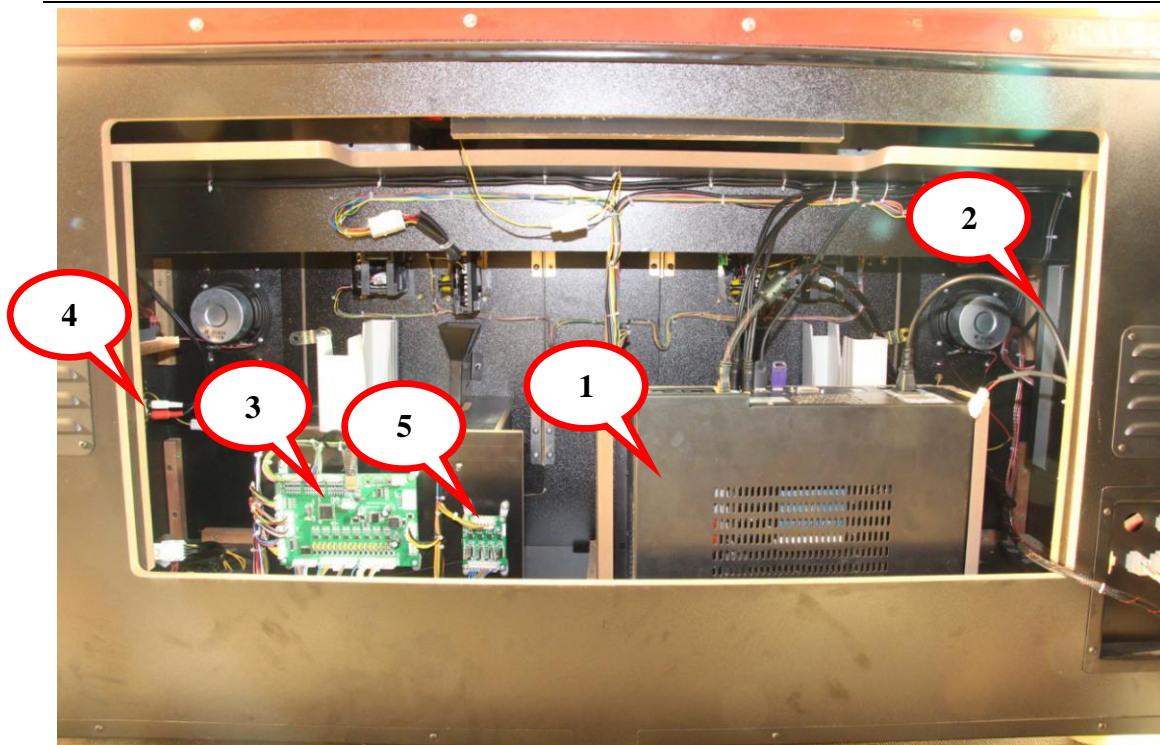

No.	Name	Specification	Quantity
1	Industrial computer (mid tower)	(MT-A5235) A55/5300/ memory 2G*2 hard disk16G	1
	Memory	DDR3 4G	1
	GPU	R7350	1
2	2.0-A amplifier board	Y-218B	1
	Stereo audio cable	3.5 double RCA 3M*2	1
3	IO main board	MB-MINI.PCB V1.2	1
	Casing line	Zombie Land in Chinese version	1
	USB data cable	Type A/B 2m	1
4	Power amplifier 1	2+1	1
	Power amplifier 2	2+1	1
5	Vibration motor, high-power driver board	MOS DRIVER.PCB V1.0	1



## Exploded View of The Complete Machine

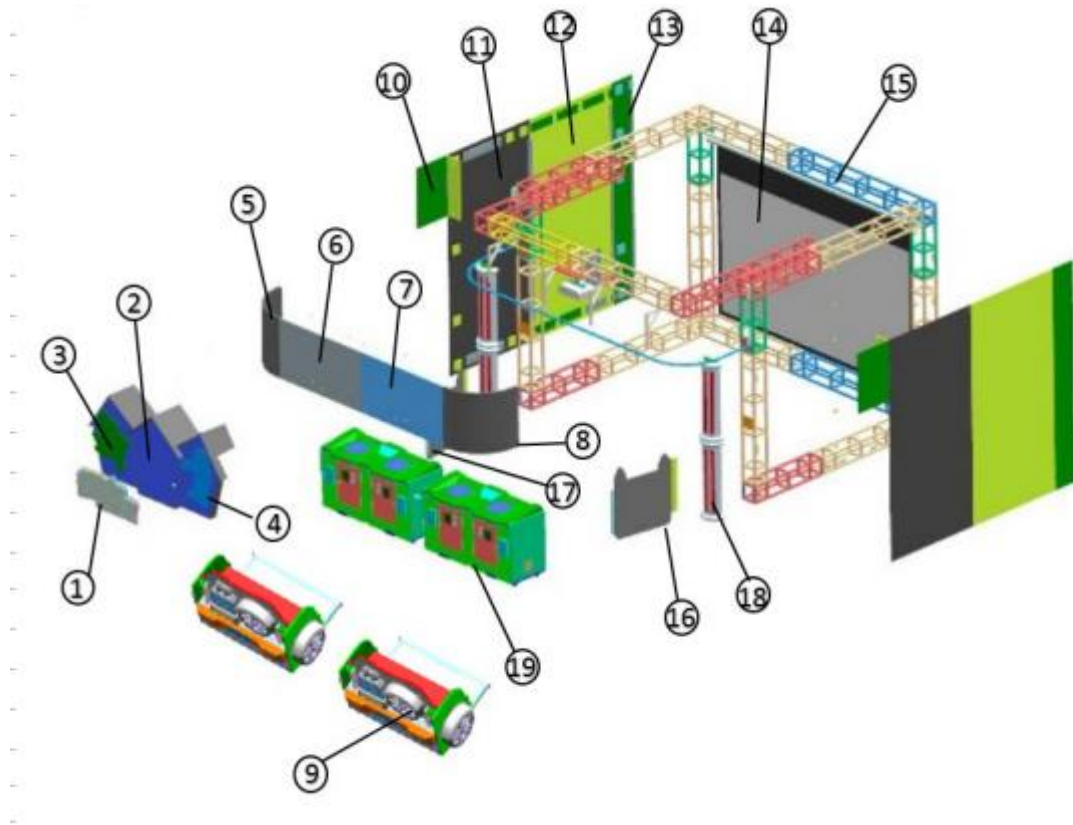

Name of materials used					
No.	Name	Figure No.	Description	Specification	Quantity
1	Front light box	A001-03-48M			1
2	Large light box	A001-03-21M			1
3	Puppet image A	A001-HM-09			1
4	Puppet image B	A001-HM-08			1
5	Scaffold edge board	A001-03-12			1
6	Scaffold front board B	A001-03-20M			1
7	Scaffold front board A	A001-03-11M			1
8	Scaffold edge board	A001-03-12			1
9	Seat				2
10	Scaffold side board	A001-03-13M			1
11	Scaffold left side board A	A001-03-42M			1
12	Scaffold left side board B	A001-03-43M			1
13	Scaffold left side board C	A001-03-44M			1
14	Projection curtain				1
15	Truss	A001-03-04			1
16	Right door breast board	A001-03-24M			1
17	Left door breast board	A001-03-26M			1
18	Scaffold light box	A001-03-05			1
19	Console				2

# Assembly Figures and Steps

## Assembly Figure of Truss

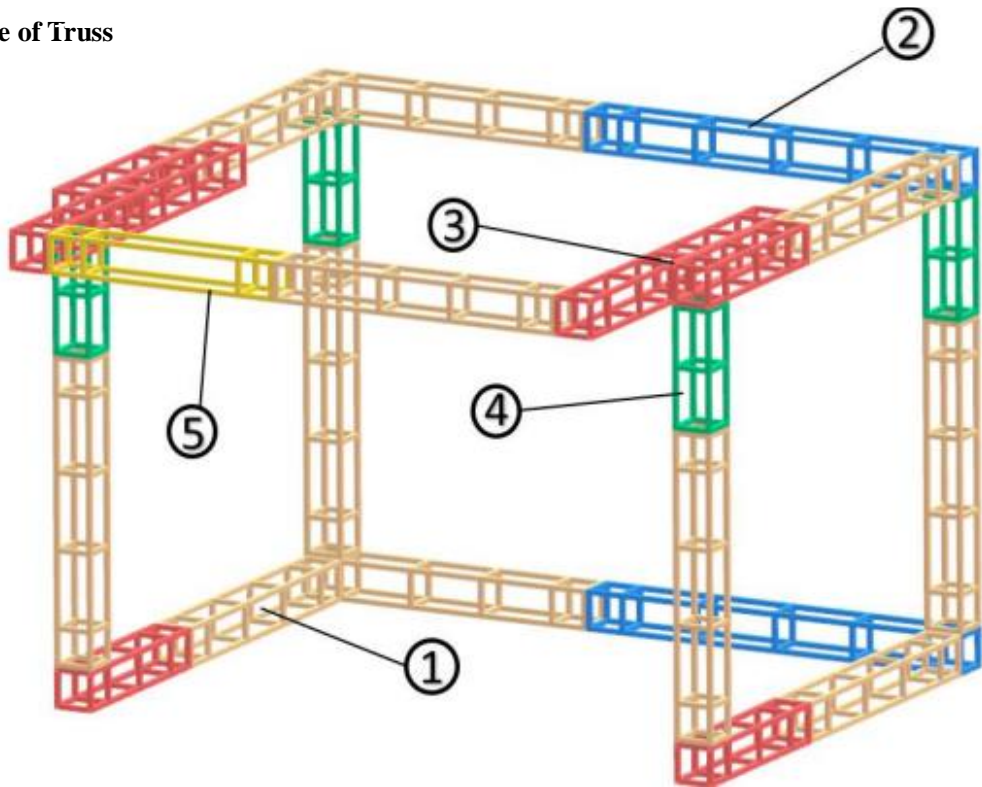

5	A001-03-29	1. 2M-Truss	Q235	25*25*T1.2	1
4	A001-03-28	1M-Truss	Q235	25*25*T1.2	8
3	A001-03-03	0.6M-Truss	Q235	25*25*T1.2	4
2	A001-03-02	1.5M-Truss	Q235	25*25*T1.2	11
1	A001-03-01	2M-Truss	Q235	25*25*T1.2	2



Step 1: Put up the truss as shown (in figure 1)

Figure 1

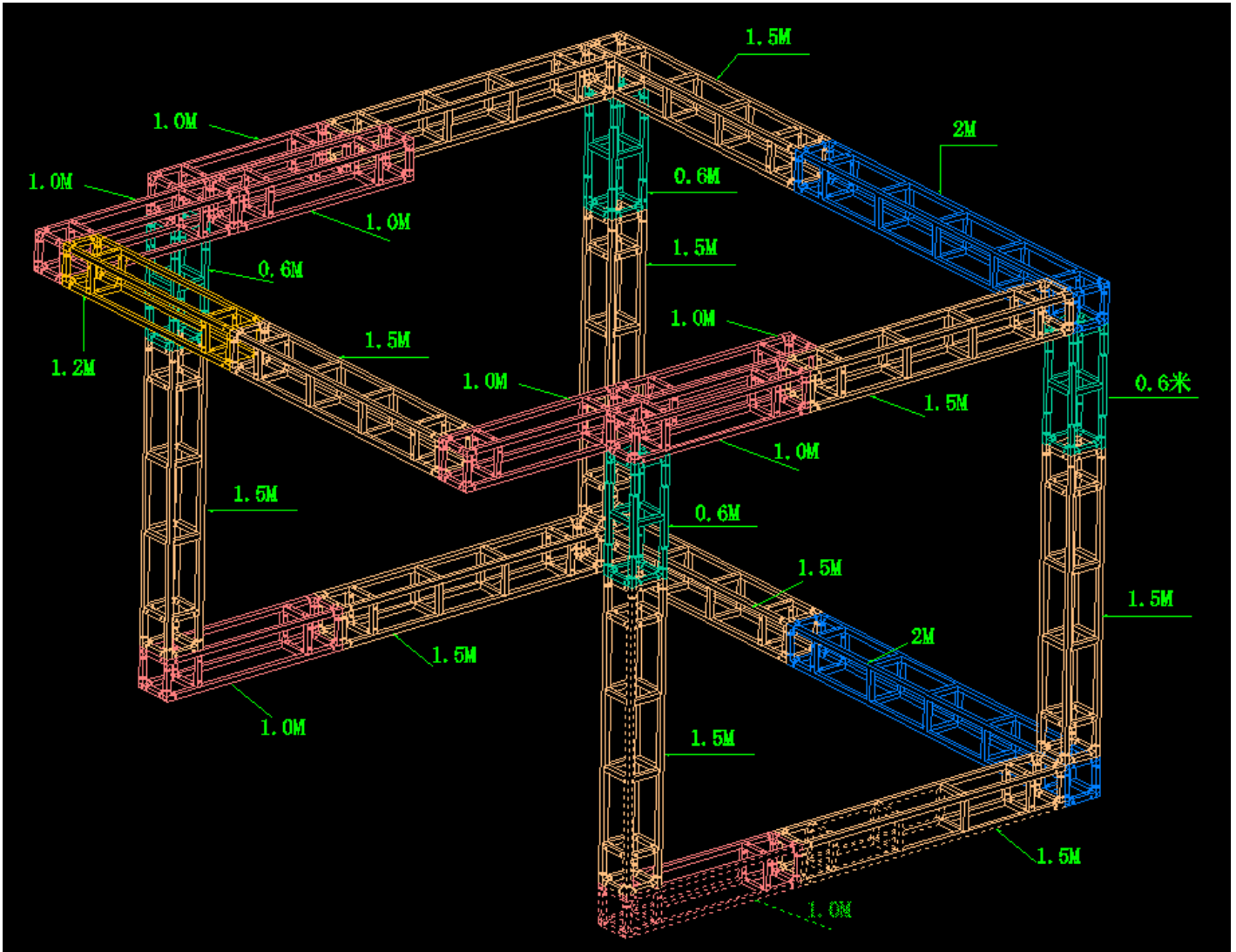

Step 2: Assembly right and left side board (figure 2)

Figure 2

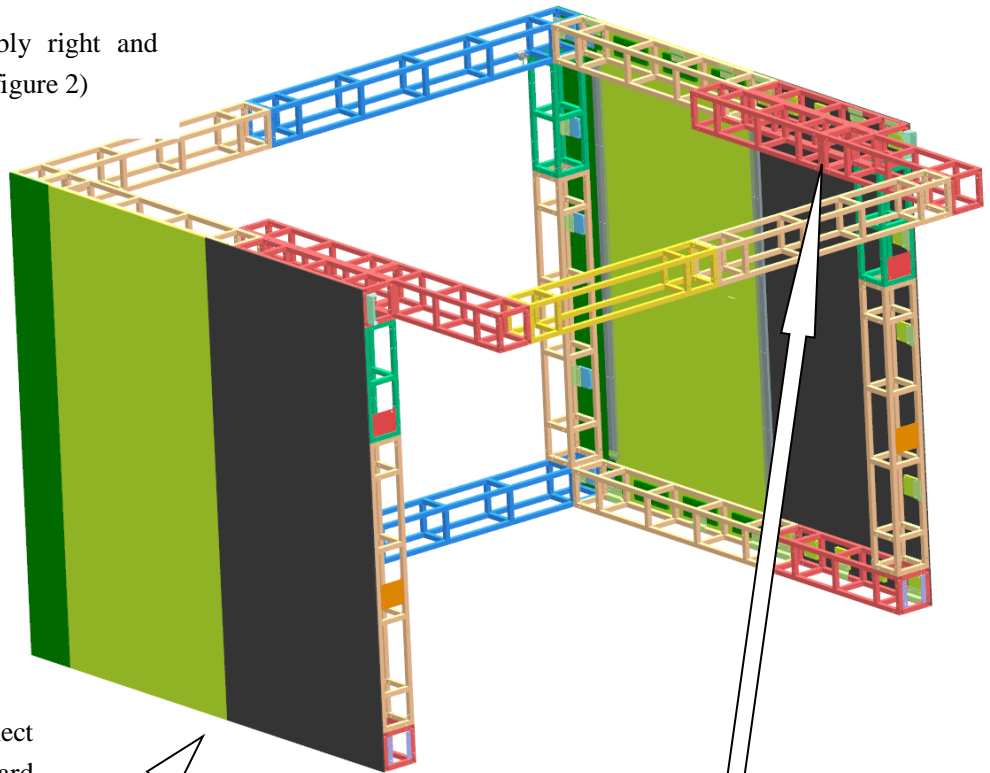

Step 3: Connect the middle board (figure 3)

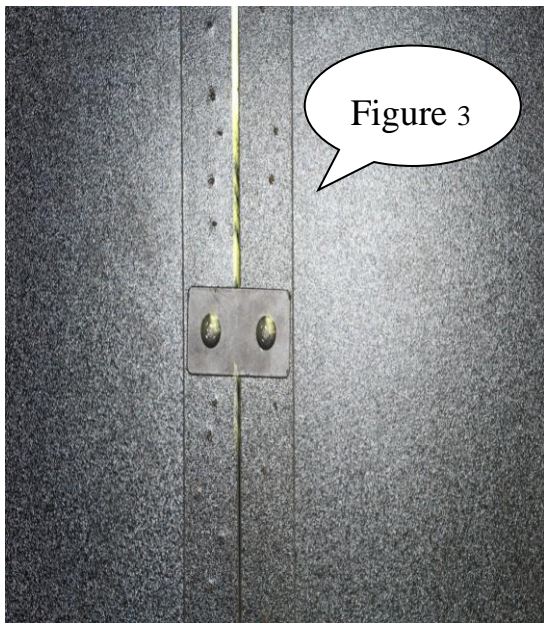
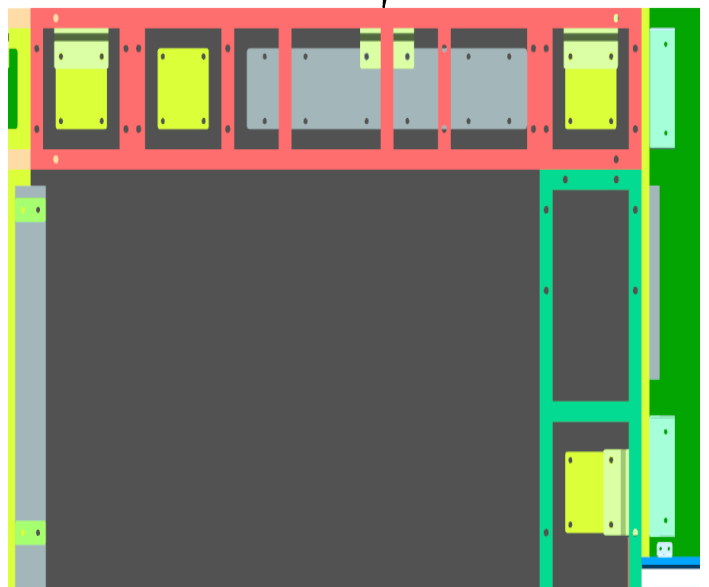

Figure 3



Step 4: Connect the boards on both sides (figure 4)

Figure 4

Step 5: Assemble the front light box board (figure 5)

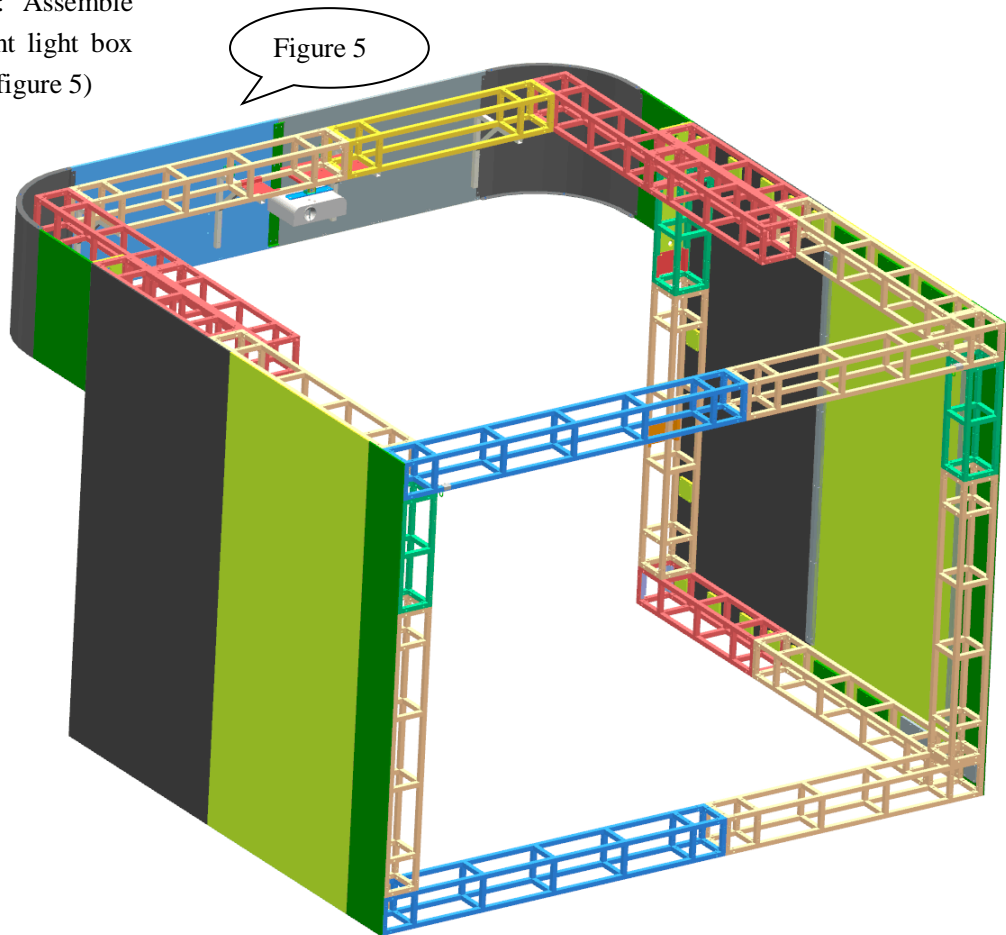

Figure (6) Assembly of right light box board and hardware of the light box

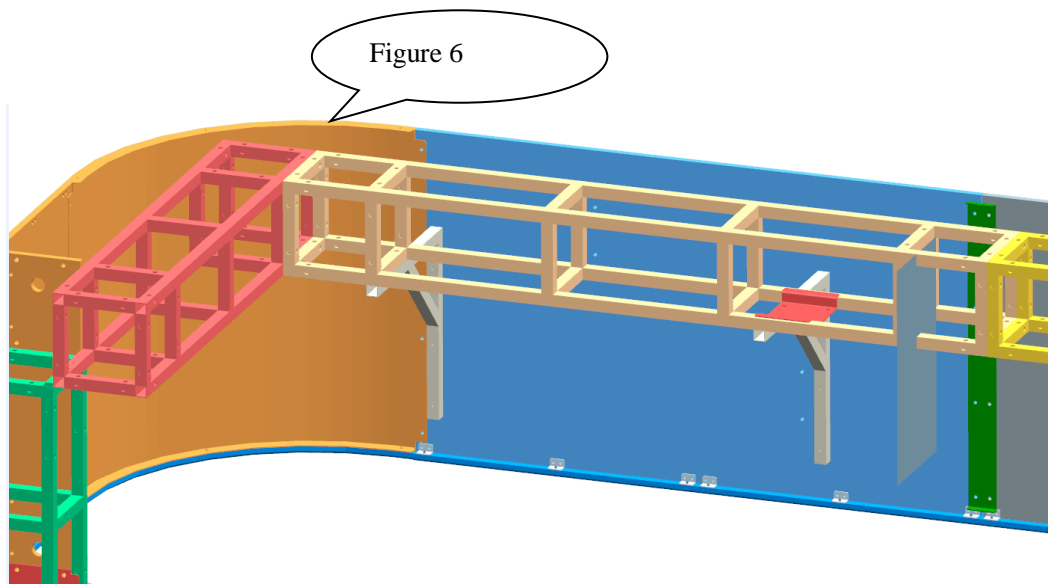

Figure (7) Assembly of top front board of the left truss

Figure 7

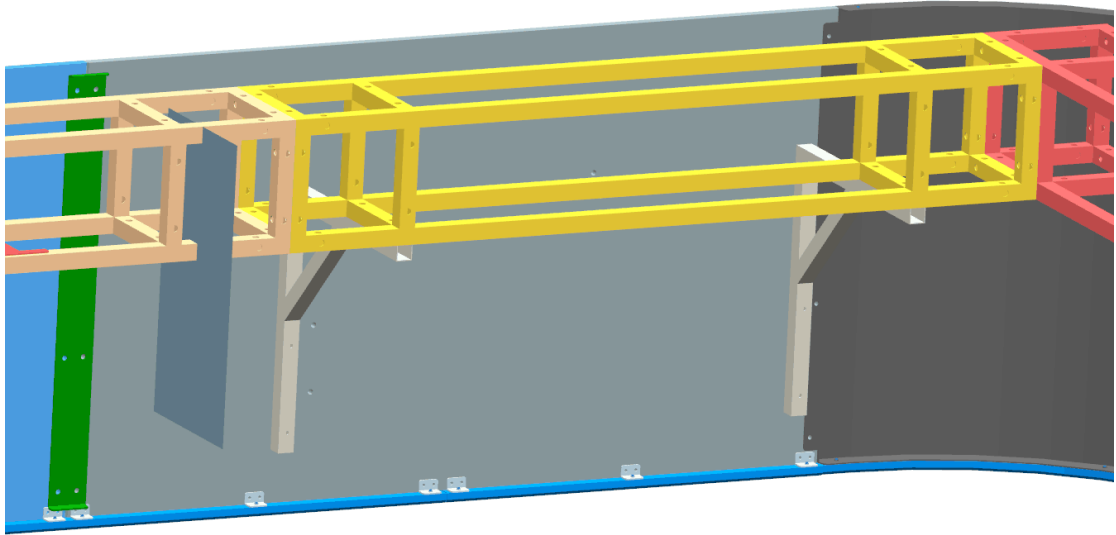

Figure (8) Assembly of the top front light board of the right truss



Figure 8

Step 4: Assembly figure (9) of the LED light strip

Figure (9)  
LED light strip

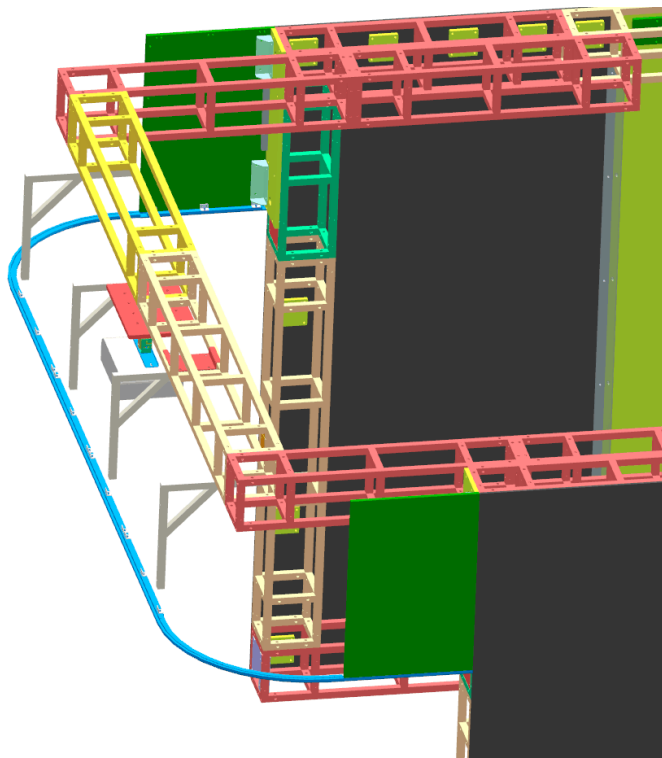
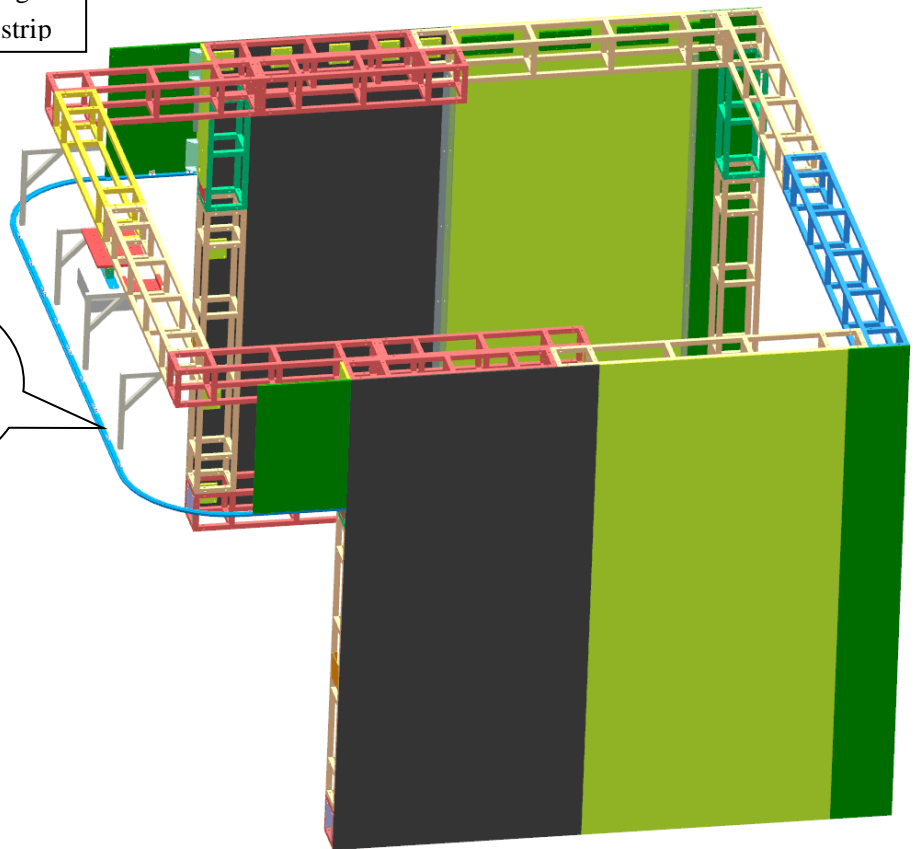

Step 5: Assembly figure (10) of the light box

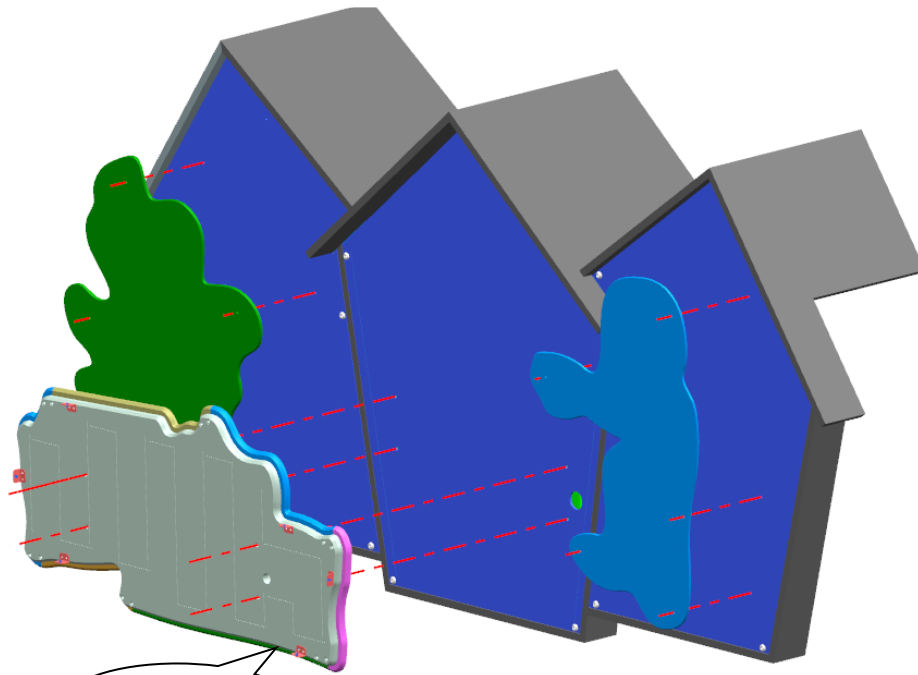
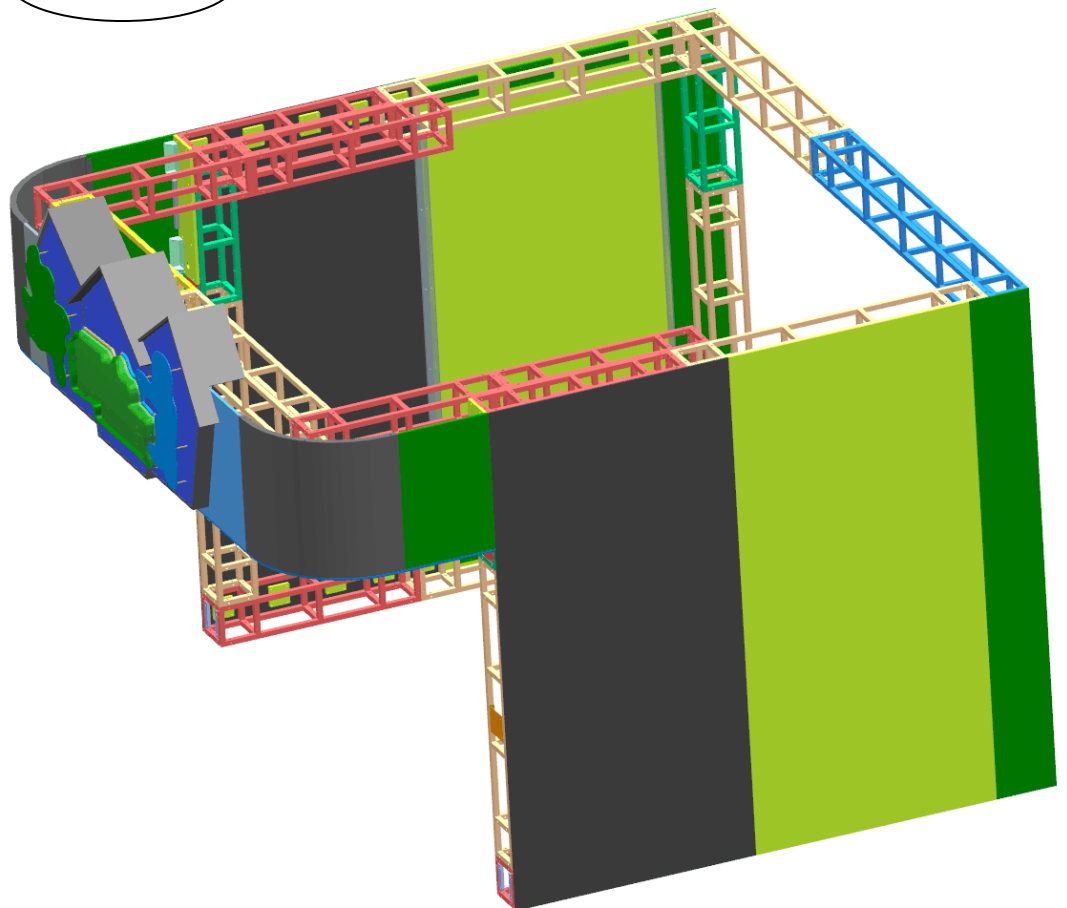
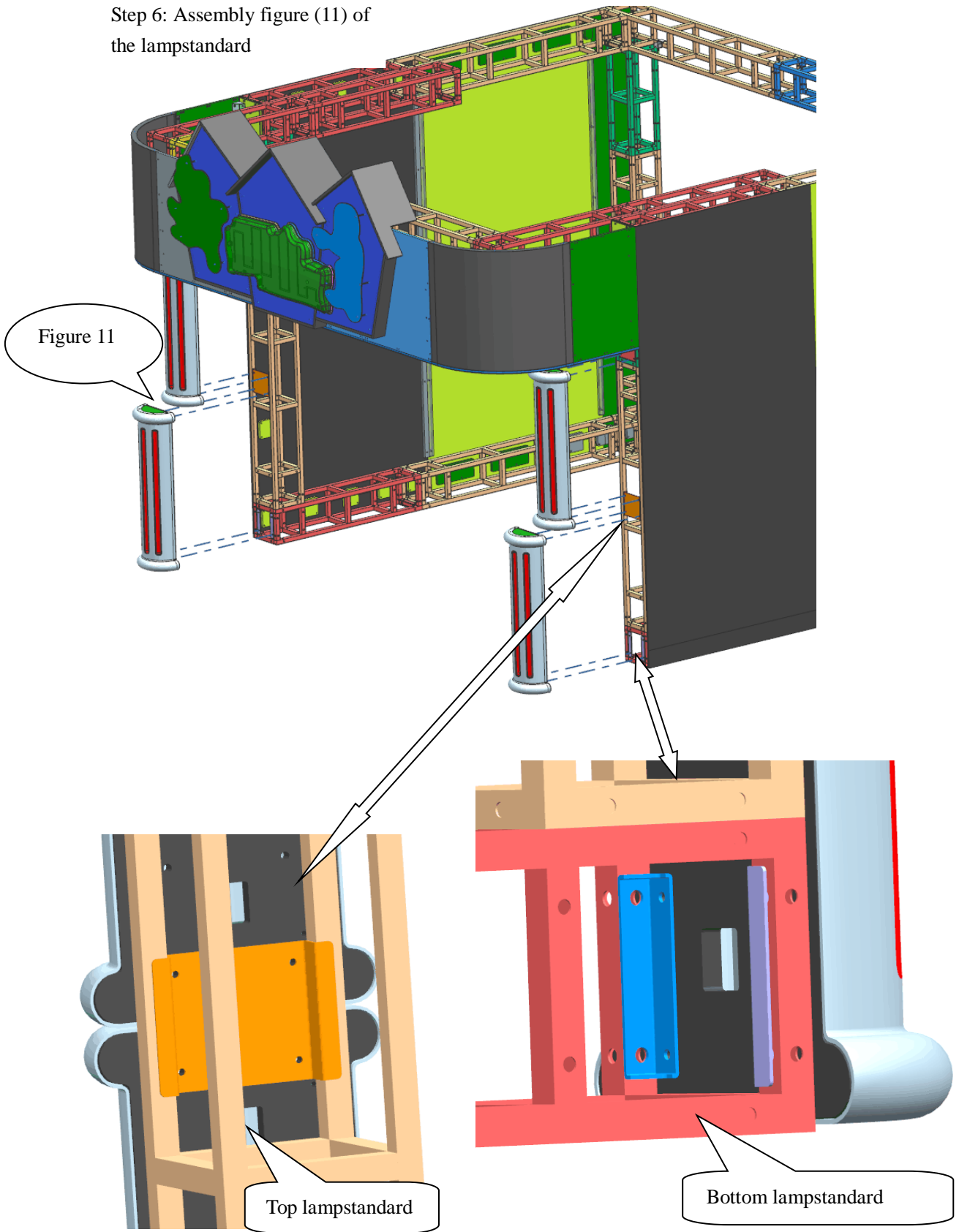

Figure 10





Step 6: Assembly figure (11) of the lampstandard



Step 7: Assembly figure (12) of the projector

Figure 12



Step 8: Assembly figure (13) of the projection screen

figure13

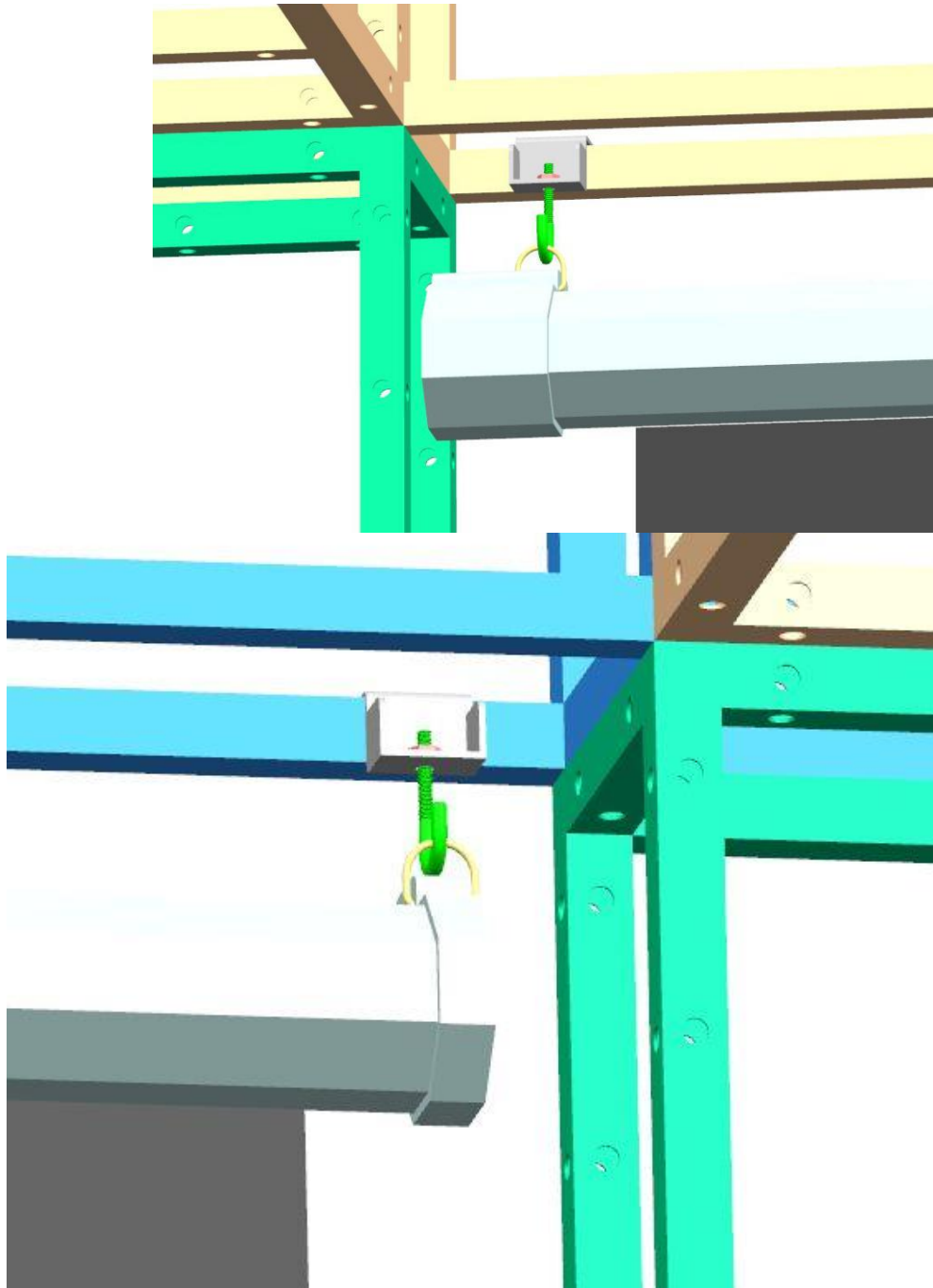

Step 9: Assembly figure (14) of the left side dam-board

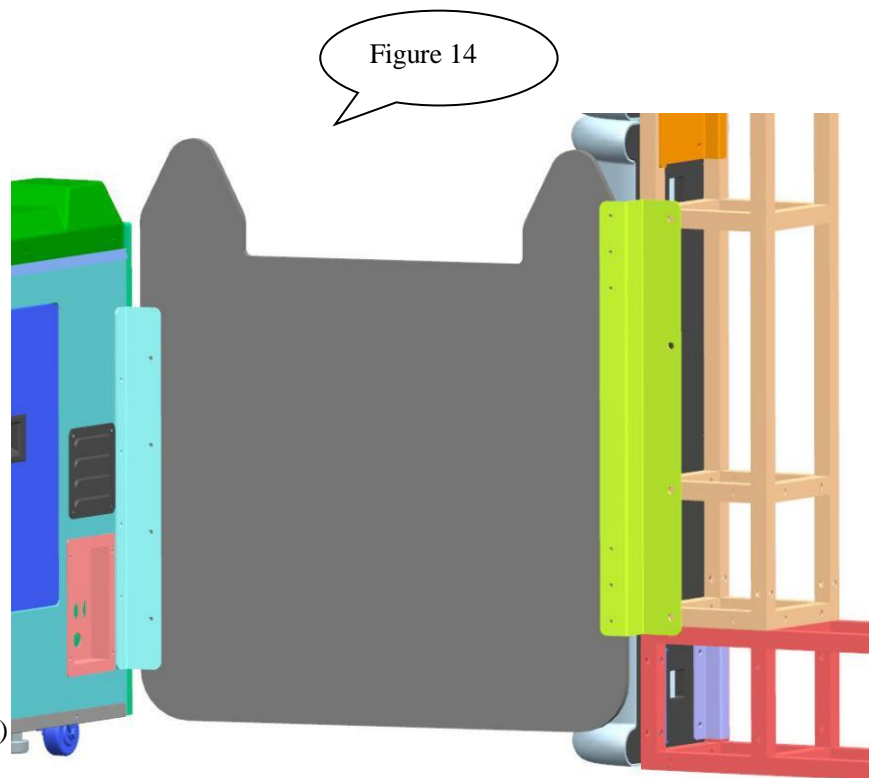

Step 10: Assembly figure (15) right side dam-board

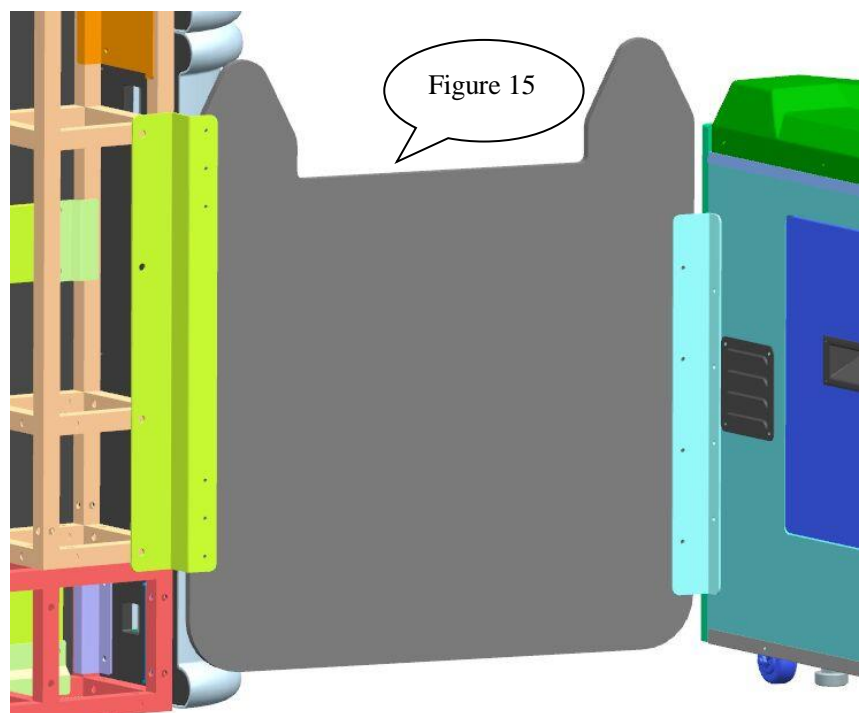

Step 11: Assembly figure  
(16) of the consoler

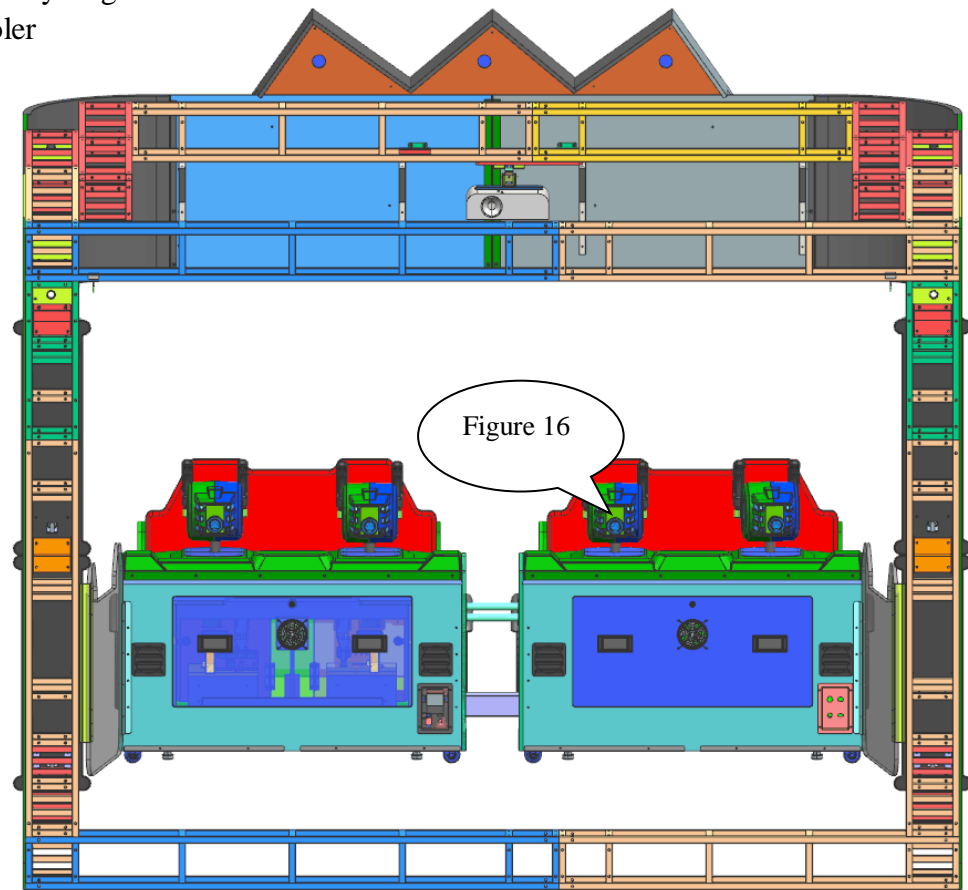

Step 12: Assembly figure (17)  
of the seat

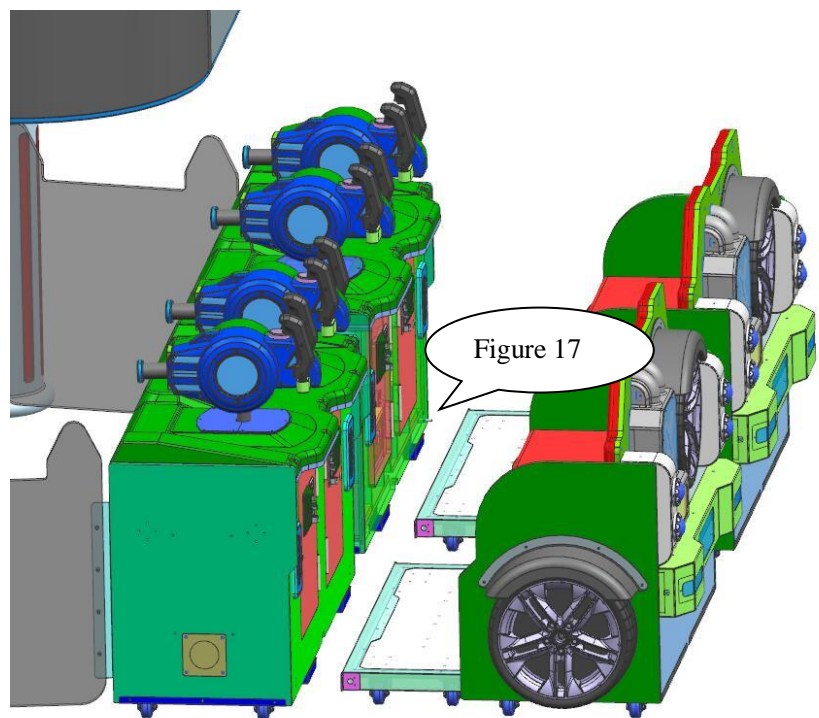

# I/O Board List

## Zombie War IO V1.0

### Input IO:

INPUT	Content	INPUT	Content	INPUT	Content
IN1	1P Coins	IN9	3P Coins	IN17	
IN2	1P Start Button	IN10	3P Start Button	IN18	
IN3	1P Shoot Button	IN11	3P Shoot Button	IN19	
IN4	1P Ticket	IN12	3P Ticket FeedBack	IN20	
IN5	2P Coins	IN13	4P Coins	K1	Test Button
IN6	2P Start Button	IN14	4P Start Button	K2	Server Button
IN7	2P Shoot Button	IN15	4P Shoot Button	K3	Ticket Repair
IN8	2P Ticket	IN16	4P Ticket FeedBack	K4	Sure Button

注: IN1-20 is standard input, 21-24 is setting input

### Output IO:

OUTPUT	Content	OUTPUT	Content	OUTPUT	Content
OUT1	1P Gun Light	OUT9	Seat Light	OUT17	1P Start Light
OUT2	2P Gun Light	OUT10	Machine Light1	OUT18	2P Start Light
OUT3	3P Gun Light	OUT11	Machine Light2	OUT19	3P Start Light
OUT4	4P Gun Light	OUT12	Machine Light3	OUT20	4P Start Light
OUT5	MachineLight Red	OUT13	Coins Table	OUT21	1P Ticket
OUT6	MachineLight Green	OUT14	Ticket Table	OUT22	2P Ticket
OUT7	MachineLight Blue	OUT15	Blower 1	OUT23	3P Ticket
OUT8	Flash Light	OUT16	Blower 2	OUT24	4P Ticket

注: OUT1-16 MOS output electricity not exceeding 2A; 17-24 ULN2803 output electricity not exceeding 50MA

INPUT	Content	Content
COM1 (J12)	TX	
	RX	
	GND	
COM2 (J13)	TX	
	RX	
	GND	

### ADC IO:

INPUT	Content	Content
AD1-2 (J3)	+3.3V	
	AD1	1P AD X
	AD2	1P AD Y
	GND	
AD3-4 (J4)	+3.3V	
	AD3	2P AD X
	AD4	2P AD Y
	GND	
AD5-6 (J5)	+3.3V	
	AD5	3P AD X
	AD6	3P AD Y
	GND	
AD7-8 (J6)	+3.3V	
	AD7	4P AD X
	AD8	4P AD Y
	GND	

### Communication

INPUT	Content
COM1	
USB	
RF	

INPUT	Content	Content
S1-5 (J18)	GND	
	S1	1P Gun Shake Motor
	S2	2P Gun Shake Motor
	S3	3P Gun Shake Motor
	S4	4P Gun Shake Motor
	S5	
	5V	
	12V	

# Instructions on Restoring U Disk

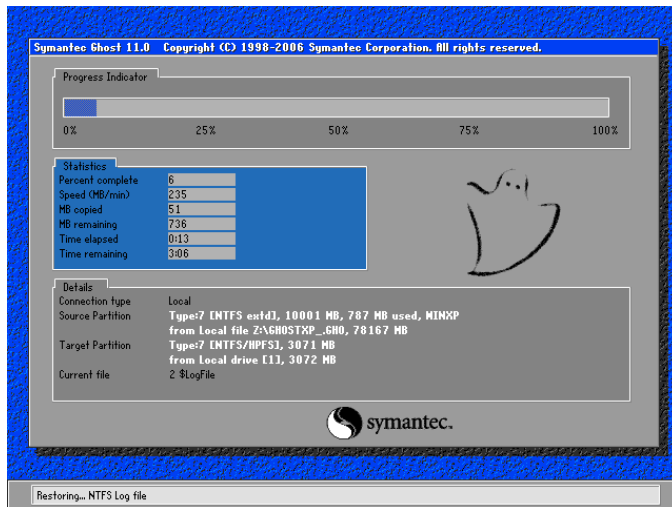

When the machine is turned off, plug the U disk into the USB port behind the host, and the U disk will restore after the machine restarts. As shown in the figure, the system is restoring, and it needs about 20 minutes.

Complete prompt. The system restoring is completed as shown in the left figure, and you can unplug the U disk.



**The system restoring needs about 20 minutes. Please do not cut off the power supply and wait patiently! Please forgive if there is any inconvenience!**



**Attention: The above technical parameters are subject to change without prior notice.**